

# FREEWAY M-Series Mobile Hoists



PRISM MEDICAL UK

*Moving, Handling and Bathing Solutions™*



The M-Series hoists are of durable steel construction which is easy to clean. The protective coating of the hoist includes FREECOTE® – our unique antimicrobial and antibacterial coating which is resistant against the hospital super bug MRSA, e-coli, salmonella and listeria.

FREECOTE® is an innovative coating which exploits the natural antimicrobial properties of silver. Silver is one of the oldest known antimicrobials and its effects are well documented.

Bacteria coming in contact with the FREECOTE® surface are destroyed. Independent lab tests show that bacteria was reduced by 99.99% within 24 hours of coming in contact with coating FREECOTE®.

While most antimicrobial products have no control over the release rate of the active agent, FREECOTE® works by 'release on demand'. Accelerated life testing has demonstrated that FREECOTE® will remain active for the lifetime of the product.



# FREEWAY M-Series Mobile Hoists

The Freeway M-Series of mobile hoists is the result of years of experience in developing, manufacturing and supplying hoists, combined with the knowledge gained from working closely with the professionals and caregivers who use them.

Every aspect of the M-Series has been designed to make lifting and handling easier and safer. Its compact, ergonomic design makes it perfect for use in community or nursing environments.

Now available with the option of the Freeway Quick Release System (QRS®) which allows carry bars and weigh scales to be safely and easily attached/removed without the need for tools.

## PRISM Slings

*Slings are the most important component of any hoist system as they are the interface between the client and the hoist.*

Prism offer a comprehensive range in a variety of designs and materials.

A customisation service is offered to provide a unique client specific sling solution.

All Prism slings have colour coded bindings to indicate the sling size and unique colour coded loops to ensure the sling is correctly positioned and connected to the hoist.

<b>PRISM</b> SLING SIZE GUIDE	<b>XX LARGE</b>
	<b>X LARGE</b>
	<b>LARGE</b>
	<b>MEDIUM</b>
	<b>SMALL</b>
	<b>JUNIOR</b>
	<b>CHILD</b>

### Slings size guide

Is provided for reference on the boom of the hoist.







### Ergonomically designed handset

Simple 4 button operation of the hoist.

Diagrams on the handset further enhance ease of operation.

The handset can be conveniently positioned on any part of the hoist frame when not needed.



### Ergonomically profiled push handles

Designed in conjunction with the REBA assessment tool.

Allows for the safe moving and positioning of the hoist.

The control box is recessed within the handles to avoid accidental contact with the emergency stop button.

### Control box

Includes controls that can be used to operate the hoist in the unlikely event of failure of the handset.



### Emergency stop button

Situated on control box.

Push in to operate and rotate clockwise to reset.



### On board charging

There is also the option of 'off board' charging of the battery pack which offers added flexibility.



### Rear foot bar

Helps to negotiate the hoist over uneven floor surfaces and door thresholds.





# QRS

## Quick Release System

Allows carry bars and weigh scales to be easily attached/removed.

QRS and weigh scales for the M-Series are options.



## Freeway spreader bar

The unique contoured 3 hook spreader bar creates optimum space for the client and caregiver.

It accommodates most designs of slings and lifting requirements.



## Actu-log

Included as standard – it records and displays the hoist usage. It has the potential to increase the actuator lifespan.



## Manual emergency lowering facility



Is provided for use in the unlikely event of a power or control box failure.



## Powered leg opening (as standard)

Offers smooth, controlled leg opening to the desired position for a stable and safer lift without restricting access around chairs and beds.

## Heavy duty 100 mm castors

Makes the hoist easy to manoeuvre on all surfaces.

'Bump guards' on front castors and lockable castors on rear.

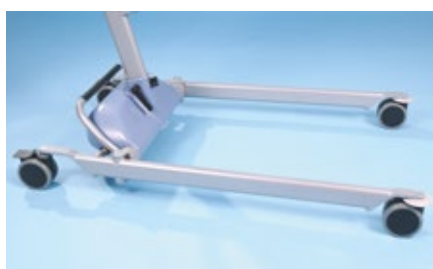

# Technical Specifications

Model Specification	M150	M175
Maximum Weight Capacity	150	175
Maximum Lifting Height	1630	1770
Minimum Lifting Height	540	600
Internal Leg Open	1020	1040
Internal Leg Closed	620	620
Overall Length	1140	1240
Spreader Bar at Max Reach	1040	1240
Reach at Max Height	520	560
Reach at Min Height	420	500
Max Reach	735	810
Turning Radius	1200	1300
Legs Open – External Width	1120	1140
Legs Open – Internal Width	1020	1040
Legs Closed – External Width	720	720
Legs Closed – Internal Width	620	620
Overall Height of Legs	123	123
Ground Clearance	50	50
Front Twin Castors	100	100
Rear Braked Castors	100	100
Weights	M150	M175
Mast & Boom inc all fixings	15	19
Base Assembly	16	18
Assembled Unit	33	39
Battery	2	2

(Dimensions in mm and weights in kg)

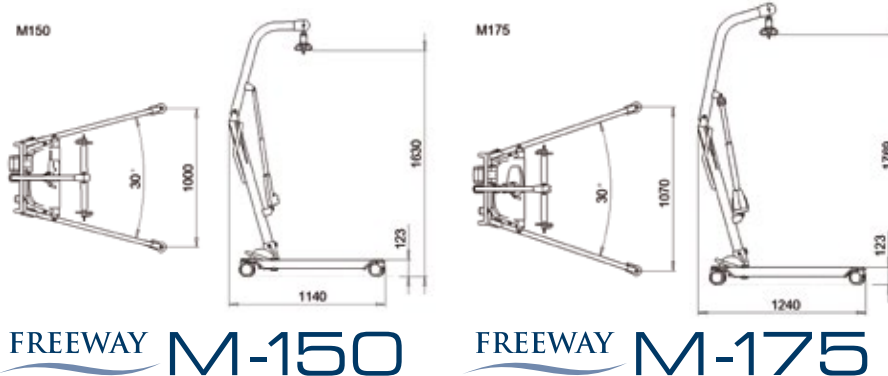

**FREEWAY M-150**

**FREEWAY M-175**

 **FULL 2 YEAR WARRANTY** (excludes batteries)

All Freeway mobile hoists are manufactured in the UK to meet and exceed all relevant design, safety and quality standards.

✓ BS EN ISO 10535:2006 Compliant 'Hoists for the transfer of disabled persons – Requirements and test methods'

## Community Care

### Prism Medical UK – Westholme Division (Northern Region)

Unit 4 Jubilee Business Park,  
Jubilee Way, Grange Moor, Wakefield,  
West Yorkshire WF4 4TD UK  
Tel: +44 (0) 844 980 2260  
Fax: +44 (0) 844 980 2261  
E-mail: info@westholme.co.uk  
www.prismmedical.co.uk

### Prism Medical UK – Westholme Division (Southern Region)

Unit 7, Saracen Industrial Estate,  
Mark Road, Hemel Hempstead,  
Hertfordshire HP2 7BJ UK  
Tel: +44 (0) 844 980 2263  
Fax: +44 (0) 844 980 2264  
E-mail: info@westholme.co.uk  
www.prismmedical.co.uk

### Prism Medical UK – Liftech Division & Test Valley Division

Unit 42 South Hampshire Industrial Park, Totton,  
Southampton, Hampshire SO40 3SA UK  
www.prismmedical.co.uk

### Liftech Division

Tel: +44 (0) 844 980 2272  
Fax: +44 (0) 844 980 2273  
E-mail: sales@liftechsystems.co.uk

### Test Valley Division

Tel: +44 (0) 844 980 2269  
Fax: +44 (0) 844 980 2270  
E-mail: admin@testvalleymobility.co.uk

### Prism Medical UK – Carefree Division

13 - 15 Pennington Street, Hindley,  
Wigan, Lancashire WN2 3AH UK  
Tel: +44 (0) 844 980 2266  
Fax: +44 (0) 844 980 2267  
E-mail info@carefreelifting.co.uk  
www.prismmedical.co.uk

### Prism Medical UK - Movement2 Division

Unit 8 The Warren,  
East Goscote Industrial Estate,  
East Goscote, Leicestershire LE7 3XA  
Tel: +44 (0) 844 980 2281  
Fax: +44 (0) 844 980 2282  
E-mail: mail@movement2.co.uk  
www.movement2.co.uk

## Long Term Care

### Prism Medical UK – Long Term Care

Unit 4 Jubilee Business Park,  
Jubilee Way, Grange Moor, Wakefield,  
West Yorkshire WF4 4TD UK  
Tel: +44 (0) 844 980 2260  
Fax: +44 (0) 844 980 2261  
E-mail: careinfo@westholme.co.uk  
www.prismmedical.co.uk

### Prism Medical UK – Saluss Division

Unit 1, Tir Llwyd Industrial Estate, St Asaph Avenue,  
Kinnel Bay, Rhyl, Conwy LL18 5JZ UK  
Tel: +44 (0) 844 980 2290  
Fax: +44 (0) 844 980 2291  
E-mail: helpdesk@saluss.co.uk  
www.prismmedical.co.uk

## Acute Hospital Care

### Prism Medical UK – Healthcare Division

Unit 4, Crispin Court, Newbiggin Lane, Newcastle Upon  
Tyne, Tyne & Wear NE5 1BF UK  
Tel: +44 (0) 844 980 2278  
Fax: +44 (0) 844 980 2279  
E-mail: healthcareinfo@prismmedical.co.uk  
www.prismmedical.co.uk

### Prism Medical UK – APLS Division

Unit 4, Crispin Court, Newbiggin Lane,  
Newcastle Upon Tyne, Tyne & Wear NE5 1BF UK  
Tel: +44 (0) 844 980 2275  
Fax: +44 (0) 844 980 2276  
E-mail: info@assured-pls.com  
www.prismmedical.co.uk

